

NAVIGATOR 6500



Quality Made In The USA



 **COVENANT LIFT**

PO Box 729

Social Circle, Georgia 30025

770-855-7019 Office | 770-464-3417 Fax

www.covenantlift.com

Standard Features

12ft. Mast
 Poclain Wheel Motors
 Mounting Kit w/Machine
 Side Shift
 Dual Action Parking Brake
 Self-Sealing Tires
 Hydraulic Oil Cooler

Options

Hand Throttle
 110 Volt Block Heater
 Block Forks
 Load Backrest
 8, 10, 12 ft Mast
 Back Up Alarm and Strobe Light

NAVIGATOR'S ultra-heavy duty-mast, dual action parking brake and many other standard features are packaged in the 6500 series in order to provide a machine that will get the toughest jobs done. The 6500 is a self-loading all terrain forklift designed for your heavy duty lifting needs. Lumber, cement, roofing materials and almost any palletized material can easily be transported over even the roughest terrain. The mounting system is designed to reduce stress while on the truck and allows the operator to load/unload in less than one minute.

General Specifications

Capacity @ 24" Load Center	6500 lbs.
Lift Height (optional)	12 Ft.
Lift Height (optional)	10 Ft.
Overall Height	104.5 In.
Min. Mounted Overhang	75 In.
Width	100 In.
Weight (ready to operate)	6250 Lbs.
Mast Tilt	8? β-----à
Side Shift	5 In.
Frame Opening	60 In.
Fork Travel	30 In.
Drive Tires	(3) 31x15.5x15
Transmission	Hydrostatic Cooled Diesel
Engine	60HP Water Cooled Diesel
Max Travel Speed	8 MPH.
Nav-Reach (optional)	Yes
Automotive control (optional)	Yes
Jumbo Caster (optional)	No

*Information subject to change without prior notice

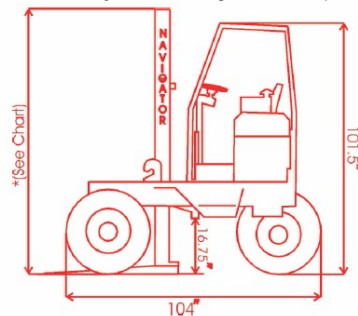

- *Mast Height
- *(6ft. Mast)... 104"
- *(8ft. Mast)... 80"
- *(10ft. Mast)... 92"
- *(12ft. Mast)... 104"

